

March 2018

# Fully Automated Ship Resistance Prediction using the Naval Hydro Pack

Inno GATIN<sup>a,1</sup>, Vuko VUKČEVIĆ<sup>a</sup>, Vanja ŠKURIĆ<sup>a</sup>, Hrvoje JASAK<sup>a</sup>

<sup>a</sup>*Faculty of Mechanical Engineering and Naval Architecture - University of Zagreb, Croatia*

**Abstract.** A numerical environment for efficient assessment of ship resistance using CFD is presented in this paper. Predicting ship resistance in calm water with the *Naval Hydro Pack* can be performed within a few hours, including grid generation, computation and post-processing of results. Being able to rapidly predict ship resistance renders CFD a cost-effective design tool, since a hull form designer can evaluate multiple variants of hull geometry quickly. The process of setting up, running and post-processing is accelerated by automating the process to a high level, significantly decreasing the number of manual work effort. In this paper the capabilities of the *Naval Hydro Pack* are demonstrated by calculating steady resistance for three different benchmark hull forms, where time for pre-processing, processing and post-processing is reported. On average, it took two and a half hours to obtain steady state results per hull form, including set-up, computational time and data analysis. Results are validated against available experimental data showing accuracy with errors below 4%, which is acceptable for early design stage.

**Keywords.** Steady Resistance, Computational Hydrodynamics, CFD, Naval Hydro Pack

## 1. Introduction

This paper presents a highly automated procedure for assessing ship resistance in calm water using Finite Volume (FV) based CFD. *Naval Hydro Pack* based on open-source *foam-extend* [1] software is used as the CFD module, while *cfMesh* [2] is used for automatic grid generation. Python based top-level algorithm is used to automate the procedure from input geometry to result post-processing. High level of automation reduces the number of man-hours, while the efficiency of the code keeps the required computational resources at a low level. With a capable CFD engineer, ship resistance can be assessed accurately in two to three hours in total, taking as low as one man-hour for set-up and post-processing. Hence, the numerical framework provides highly efficient ship design tool, allowing multiple hull forms with high-fidelity performance assessment in the early design stage.

The numerical environment is demonstrated by performing resistance calculations for three benchmark ships with available experimental data. The three benchmark hull forms are: KCS (KRISO Container Ship), JBC (Japan Bulk Carrier) and DTMB (David-

---

<sup>1</sup>Corresponding Author: Inno Gatin, Faculty of Mechanical Engineering and Naval Architecture - University of Zagreb, Croatia; E-mail: inno.gatin@fsb.hr

March 2018

Taylor Model Basin) 5512 hull. Results are compared to experimental values showing the accuracy of the developed numerical framework. Additionally, required man-hours and computational time is reported with a break-down from pre-processing to post-processing.

## 2. Numerical Framework

The numerical framework enabling rapid steady-state ship resistance calculation comprises the following:

1. Pre-processing:
  - A Python based automated set-up and execution system code is developed which automatise the entire process with minimum input parameters. The environment is optimised for displacement hulls,
  - cfMesh open-source software is used for automatic grid generation, where years of experience and best practice are employed to generate a good quality near-hull computational grid,
  - A special mesh assembly procedure has been developed where a combination of different foam-extend software utilities is used to extrude the computational grid in order to obtain a sufficiently large computational domain, while keeping the cell count acceptably low,
  - Simulation is set-up automatically using Python, where best-practice settings are employed to obtain high accuracy and performance.
2. Processing:
  - The flagship numerical solver of the Naval Hydro Pack called nava1Foam is used for the CFD simulation. The details regarding the numerical solver and the Naval Hydro Pack are given below.
3. Post-processing:
  - Python based post-processing code is used to extract ship resistance, and to generate wake field plots in the propeller plane.

### 2.1. Numerical Model

A two-phase, incompressible, viscous and turbulent flow is governed by the continuity and momentum equation [4]:

$$\nabla \cdot \mathbf{u} = 0, \quad (1)$$

$$\frac{\partial \mathbf{u}}{\partial t} + \nabla \cdot ((\mathbf{u} - \mathbf{u}_M) \mathbf{u}) - \nabla \cdot (v_e \nabla \mathbf{u}) = -\frac{1}{\rho} \nabla p_d. \quad (2)$$

In Eqs. 1 and 2,  $\mathbf{u}$  presents the velocity field,  $\mathbf{u}_M$  denotes the velocity of the numerical grid [3],  $v_e$  stands for effective kinematic viscosity comprising kinematic fluid velocity and turbulent viscosity.  $\rho$  denotes the phase-wise fluid density field, while  $p_d$  stands for dynamic pressure, defined as:  $p_d = p - \rho \mathbf{g} \cdot \mathbf{x}$ . Here,  $\mathbf{g}$  and  $\mathbf{x}$  present the constant gravitational acceleration and radii vector, respectively.

The free surface dividing the two phases is convected using the Volume of Fluid (VOF) method, where the interface compression strategy is employed following [5]:

$$\frac{\partial \alpha}{\partial t} + \nabla \cdot (\mathbf{u}\alpha) + \nabla \cdot (\mathbf{u}_r \alpha (1 - \alpha)) = 0, \quad (3)$$

where  $\alpha$  stands for the water volume fraction and  $\mathbf{u}_r$  is the interface-normal compression velocity.

In the Naval Hydro Pack, free surface discontinuities are treated with specialised interface-corrected discretisation schemes based on the Ghost Fluid Method (GFM) [4]. The GFM produces in a one-cell sharp interface with respect to dynamic pressure and density fields, mitigating problems related to non-physical smearing of the interface and spurious air velocities. In order to calculate dynamic sinkage and trim, rigid body motion equations are integrated in quasi-time until convergence. A geometric integration method is used to evolve the rigid body motion equations [6] while Lagrange multipliers are employed to confine the remaining degrees of freedom. In order to accelerate the convergence of dynamic sinkage and trim, artificial damping is added for the relevant degrees of freedom corresponding to critical damping of the oscillatory system. For turbulence modelling,  $k-\omega$  SST turbulence model is used.

### 3. Numerical Simulations

Prediction of calm water resistance for three benchmark hull forms is presented in this section, comprising grid generation, result comparison and man-hours and computational time requirements. All simulations are performed on 64 cores of Intel Xeon Processors, E5-2637 v3, 15M Cache, 3.50 GHz, while a desktop PC is used for generating computational grids.

Tab. 1 shows ship characteristics for the KCS, JBC and DTMB 5512 hull forms in full scale, where  $\lambda$  denotes the model scale. All simulations are performed in model scale to permit direct comparison with the experiment. Experimental values for KCS and JBC are found on the website of Tokyo 2015: A Workshop on CFD in Ship Hydrodynamics [7]. The experimental values for the DTMB 5512 hull are taken from the web site of the Iowa Institute of Hydraulic Research [8].

**Table 1.** Ship characteristics

Item	KCS	JBC	DTMB 5512
$L_{pp}$ , m	230	280	142
$\nabla$ , m <sup>3</sup>	52030.0	178369.9	8702.7
$V$ , kt	24	14.5	14.6
$F_r$	0.26	0.142	0.201
$\lambda$	31.6	40	46.6

#### 3.1. Grid Generation

Computational grids are generated based on the surface mesh and input ship data such as length, beam, draught, depth and forward speed. Hull geometry needs to be prepared in

the stereolithography (.STL) format, adhering to the coordinate system used by the grid generation algorithm. Tab. 2 shows basic grid information for the three benchmark hulls, including the computational time needed for grid generation. Figs. 1, 2 and 3 show a view of the computation grids for KCS, JBC and DTMB 5512 model, respectively.

**Table 2.** Grid characteristics and computational time for grid generation.

	KCS	JBC	DTMB 5512
No. Cells	1609281	1733267	2219751
No. Hexahedra	1576009	1699753	2183431
CPU Time, min	10	9	13

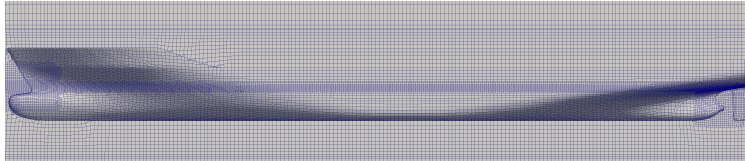

**Figure 1.** Computational grid for the KCS model.

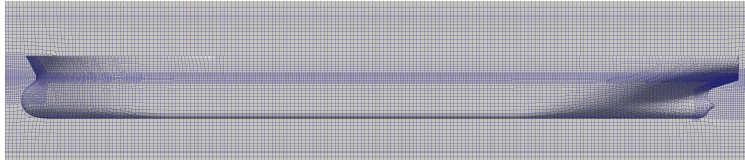

**Figure 2.** Computational grid for the JBC model.

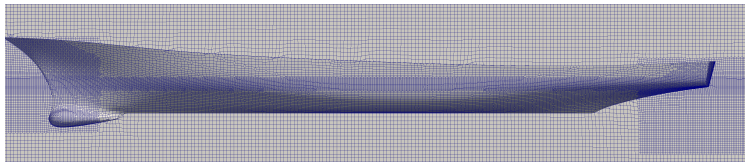

**Figure 3.** Computational grid for the DTMB 5512 model.

### 3.2. Numerical Results

The numerical framework automatically averages the steady state items such as resistance, dynamic sinkage and dynamic trim. In addition, iterative numerical uncertainties are reported for all items, which are calculated as the amplitude of result oscillation during last 200 iterations [11]. No grid convergence study is performed for these cases since this is computationally expensive and prohibitive for industrial applications. Instead, the numerical framework has been verified in the past on similar cases [11], where numerical uncertainty intervals overlap with experimental results proving the validity of the method. Convergence of the total resistance coefficient  $C_T$  for the three hull forms is

shown in Fig. 4. Apart from the numeric results, propeller plane wake field plots conforming to ITTC standards [10] are automatically generated, giving basic information for preliminary propeller design.

Results for all three hull forms with numerical uncertainties and comparison to experimental results are shown in Tab. 3. Here,  $C_t$  is the total resistance coefficient,  $\Delta$  denotes the numerical uncertainty of the item,  $EFD$  denotes the experimental values,  $E_{rr}$  denotes the error with respect to experimental values calculated as  $E_{rr,x} = (x_{EFD} - x)/x_{EFD}$ , where  $x$  denotes a general variable.  $\sigma$  denotes the dynamic sinkage in full scale, while  $\tau$  denotes dynamic trim (positive for bow up). Resistance results are within 4% of experimental values, which is acceptable accuracy from ship design point of view. For KCS and JBC the dynamic sinkage and trim are well predicted, with errors below 7 cm and  $0.02^\circ$ , respectively. For the DTMB 5512 hull, there is a discrepancy between experimental results for dynamic sinkage and trim available in [8] and [9], hence the comparison is omitted.

Figs. 5, 6 and 7 show axial flow coefficients graphs in the propeller plane for KCS, JBC and DTMB 5512 hull, respectively, automatically generated by the post-processing module. It can be seen from the plots that DTMB 5512 has the most slender form, followed by KCS. Being a bulk carrier, JBC exhibits high flow coefficients, with clearly visible hook vortices.

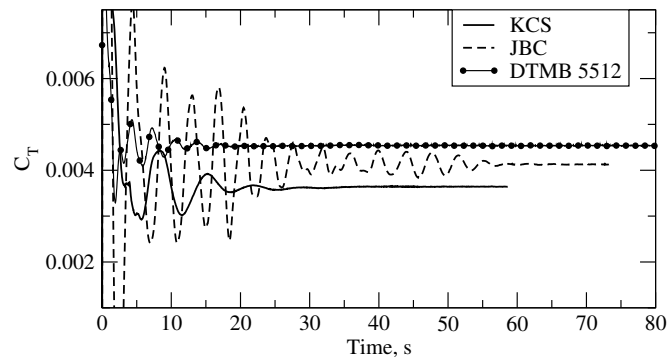

Figure 4. Convergence of total resistance for KCS, JBC and DTMB 5512.

### 3.3. Man-Hours and Computational Time

The objective of this work is to minimise the amount of man-hours and computational time needed to predict ship steady resistance using CFD. In that respect, this section presents the amount of man-hours and computational time spent for each of the benchmark hull forms, with a break-down to pre-processing, processing and post-processing.

Tab. 4 shows the man-hours break-down for individual hull forms and in total. In average, it took 1:07 man-hours for pre and post-processing per hull form. In order to establish the total time needed to get the steady resistance results, computational time for each hull form is presented in Tab. 5. It took 1:11 hours on average to converge the results on the modest cluster, while the grid generation took only 11 minutes.

The summary of the required time to obtain results for individual hulls is presented in Tab. 6. Average time needed to obtain steady resistance results for one hull form is

**Table 3.** Simulation results with comparison to experimental data.

Item	KCS	JBC	DTMB 5512
$C_t \times 10^3$	3.64	4.13	4.54
$\Delta C_t \times 10^3$	0.005	0.009	0.011
$C_{t,EFD} \times 10^3$	3.711	4.29	4.50
$E_{rr,C_t}, \%$	1.9	3.7	-0.9
$\sigma, m$	-0.441	-0.31	-0.08
$\Delta\sigma, m$	$1.0 \times 10^{-5}$	$3.75 \times 10^{-5}$	$5.7 \times 10^{-5}$
$\sigma_{EFD}, m$	-0.445	-0.24	N/A
$E_{rr,\sigma}, m$	0.004	0.07	N/A
$\tau, ^\circ$	0.182	0.104	0.21
$\Delta\tau, ^\circ$	$2.4 \times 10^{-5}$	$1.2 \times 10^{-5}$	$1.05 \times 10^{-5}$
$\tau_{EFD}, ^\circ$	0.169	0.103	N/A
$E_{rr,\tau}, ^\circ$	-0.013	-0.001	N/A

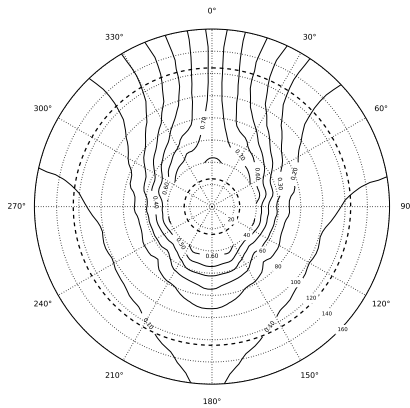

**Figure 5.** Propeller plane wake field for KCS.

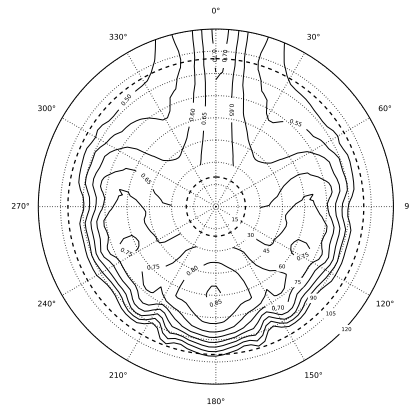
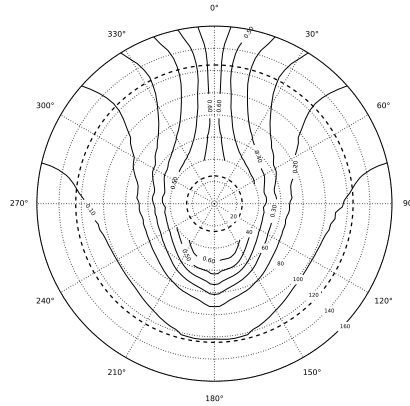

**Figure 6.** Propeller plane wake field for JBC.

two and a half hours, including man-hours and computational time. In total, it takes 7 hours and 26 minutes to pre-process, simulate and post-process three hull forms, with the assumption that all processes are performed back-to-back. In reality, a CFD engineer can pre-process the second hull form while the first is being simulated, which reduces the overall time. Even if the engineer waits until all simulations are completed, three hull forms can be numerically evaluated in one day with modest computational resources. In practical ship design process, this means that at least three different hull geometry options can be tested in a single working day using CFD.

**Table 4.** Break-down of man-hours spent on individual hull forms.

	KCS	JBC	DTMB 5512	Average	Total
Pre-processing, h	0:25	0:46	0:48	0:39	1:59
Post-processing, h	0:36	0:30	0:18	0:28	1:24
Total, h	1:01	1:16	1:06	1:07	3:23



**Figure 7.** Propeller plane wake field for DTMB.

**Table 5.** Computational time required for grid generation and running the simulations.

	KCS	JBC	DTMB 5512	Average	Total
Grid generation, h	0:10	0:09	0:13	0:11	0:32
Simulation, h	0:56	0:52	1:45	1:11	3:33
Total, h	1:06	1:01	1:58	1:22	4:05

**Table 6.** Total time required for steady state simulations, combining man-hours and computational time.

	KCS	JBC	DTMB 5512	Average	Total
Man-hours, h	1:01	1:16	1:06	1:07	3:21
CPU time, h	1:06	1:01	1:58	1:22	4:05
Total, h	2:07	2:17	3:04	2:29	7:26

#### 4. Conclusions

A numerical framework enabling rapid evaluation of ship resistance in calm water using CFD is presented in this paper. The procedure is based on the Naval Hydro Pack software, where Python based top-level execution system is developed to automatise pre and post-processing of the simulations. High level of automation reduces the required man-hours to a minimum, enabling the method to be used in realistic industrial design processes.

The presented numerical framework is tested on three benchmark hull forms comparing the results with available experimental data. Comparison of resistance, dynamic sinkage and trim is reported, showing good accuracy with prediction of total resistance within 4% error for all hull forms. Results are post-processed by the Python based top-level code, including graphical representation of flow coefficient in the propeller plane, useful for propeller design.

For the complete process of pre-processing, simulating and post-processing of all three simulations, it took 7 hours and 26 minutes including man-hours and computational time. In average, it takes **1:07 man-hours** to pre and post-process one hull form, and **1 hour and 22 minutes** of computational time to perform the calculation. Hence, for one

March 2018

hull form, steady resistance results are obtained within **2 hours and 29 minutes** from receiving the hull geometry and input parameters to the output of numeral and graphical results.

The results presented in this paper demonstrate that at least three hull form geometries can be tested using CFD by one engineer within one working day. If the differences in geometries are not large, the process can be further accelerated since the difference in solution is small, and the grid generation process remains virtually unchanged. This enables CFD to be used in everyday ship design process, since price per simulation is significantly lowered, whether the designer is relying on an in-house CFD engineer using the software or ordering the calculation from a specialised company. Note that the engineer has to command a high level of CFD skills in order to efficiently use the numerical framework.

## References

- [1] H. Jasak: *OpenFOAM: Open source CFD in research and industry*, International Journal of Naval Architecture and Ocean Engineering, 2008, Vol. 1, 89–94.
- [2] F. Juretić: *cfMesh: Advanced Meshing Tool*, cfMesh.com, Online: accessed 22 February 2017.
- [3] I. Demirdžić and M. Perić: *Space conservation law in finite volume calculations of fluid flow*, Int. J. Numer. Meth. Fluids, 1988, Vol. 8, 1037–1050.
- [4] V. Vukčević, H. Jasak and I. Gatin: *Implementation of the Ghost Fluid Method for free surface flows in polyhedral Finite Volume framework*, Computers & Fluids, 2017, Vol. 153, 1–19.
- [5] H. Rusche, *Computational Fluid Dynamics of Dispersed Two - Phase Flows at High Phase Fractions*, Imperial College of Science, Technology & Medicine, London, 2002.
- [6] A. Müller and Z. Terze: *Geometric methods and formulations in computational multibody system dynamics*, Acta Mechanica, 2016, Vol. 227, 12, 3327–3350.
- [7] National Marine Research Institute, Japan: *Tokyo 2015: A Workshop on CFD in Ship Hydrodynamics*, <http://www.t2015.nmri.go.jp/>, Online: accessed 5 March 2018.
- [8] Iowa Institute of Hydraulic Research: <http://www.ihr.uiowa.edu/shiphydro/efd-data/5512-steady/>, Online: accessed 5 March 2018.
- [9] J. Longo and F. Stern: *Uncertainty Assessment for Towing Tank Tests With Example for Surface Combatant DTMB Model 5415*, Journal of Ship Research, 2005, Vol. 49, 55–68.
- [10] ITTC: *Practical Guidelines for Ship CFD Applications*, 2011.
- [11] I. Gatin, V. Vukčević, and H. Jasak: *Validation and Verification of Steady Resistance KCS Simulations with Dynamic Sinkage and Trim of KCS using Embedded Free Surface Method*, Tokyo 2015: A workshop on CFD in Ship Hydrodynamics, Tokyo, Japan, December 2015.